

# Repairing

---

# Faucets & Valves

Faucets are sold in many different makes and models, but the common ones fall into just a few types. You'll find only two basic kinds of faucets; washer-type (or compression) faucets and washerless faucets.

Step #	1
--------	---

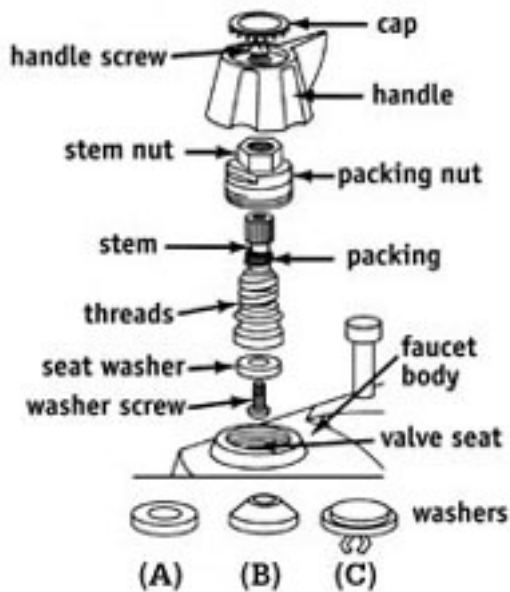

**FIG. 1** - Compression faucet

## REPAIRING A LEAKY WASHER-TYPE FAUCET

- Washer-type faucets work with a rubber or composition washer that closes onto a metal washer seat (Fig. 1). The washer can become hardened, worn or the seat wears, causing the faucet to leak. You can close the faucet tighter to stop the leaking temporarily, but this increases the internal damage to the faucet.
- To repair the leak, first turn off the water. If there's a shutoff valve beneath the fixture, turn off the water at that point. Otherwise, turn it off at the main house shutoff valve in the basement, utility room, or crawlspace. Turn off the hot water supply at the water heater.
- Take the faucet apart by removing the handle (this may not be necessary on some older faucets). Loosen the Phillips-head screw, which usually is beneath a decorative cap in the center of the handle. The cap either unscrews or snaps off when you pry it with a knife blade. If you must use pliers on decorative faucet parts, pad them with electrical tape or cloth to protect the finish. And take special care with the plastic parts found on many modern faucets. Next, lift or pry the handle off its broached

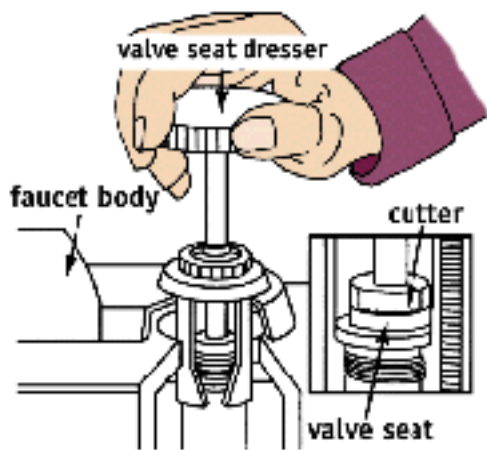

**FIG. 2** - To use a valve seat dresser, place the tool in the valve seat and turn until the seat is smooth.

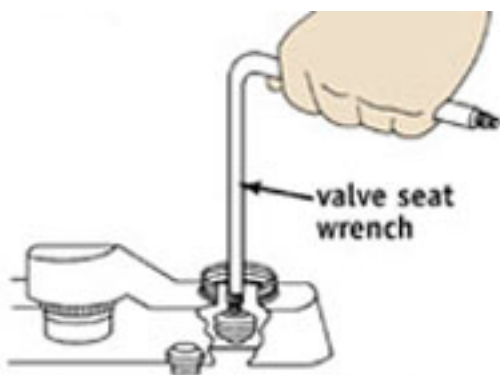

**FIG. 3** - To remove the valve seat, insert a valve seat wrench into the faucet body and turn counterclockwise.

stem. Unscrew the packing nut beneath the handle, exposing the rest of the stem. Remove the stem by rotating it in the "on" direction. It will thread out. Reinstall the handle if you have difficulty turning it (Fig. 1). Clean chips from the faucet cavity, but do not use harsh abrasives or a file.

- Examine the stem. If the threads are badly corroded or worn, take it to your retailer and get a new stem to match. Clean the stem if it's dirty.
- Now look at the washer, which is located on the lower end of the stem and held in place by a brass screw. If the washer is squeezed flat or has a groove worn in it, replace it—this should stop any dripping. Take the washer with you to your dealer to ensure an exact match in size and style. If the brass screw is damaged, too, replace it with a new brass screw.
- The washer seat is located inside the faucet body. You probably can't determine if the washer seat is causing the leak just by looking at it. Any faucet that needs frequent washer replacement obviously has a damaged seat. The seat should either be refaced with a seat-dressing tool. A seat-dressing tool is not costly. Every home with washer-type faucets needs one. Use the tool according to the manufacturer's directions, placing it in the faucet along with the packing nut. Then rotate (Fig. 2) until the seat is smooth, and blow out the chips.
- Some washer seats can be unthreaded and replaced. Check the faucet body with a flashlight to see if it has a square or hexagonal hole through its center or is slotted for a screwdriver; if so, it is replaceable. However, if the seat simply has a round hole through its center and no slots, it is not replaceable. In this case, dress it with a seat-dressing tool. To replace it, you'll need a faucet seat wrench, which comes with a combination of square and hex heads to fit most faucet seats. Turn the washer seat counterclockwise to loosen, clockwise to tighten (Fig. 3). Add a little silicone rubber sealant (RTV) or pipe joint compound around the threads of the seat before you install it to make it easier to remove during future repairs.
- It's important to install the correct type of faucet washer (Fig. 1, bottom). A swiveling washer (C) is preferable to either (A) or (B). To install washer style (C), file the shoulder off the end of the stem, drill out the threads of the screw hole. Instead of rubbing against the seat as it closes, a swiveling washer closes with a straight-down, frictionless action – this allows it to outlast fixed washers.

- Following this seat and washer service, your faucet should be like new. Put the parts back together in the reverse order of taking them apart. Spread a bit of petroleum jelly or silicone grease on the threads of the stem to lubricate the faucet's action.
  - If the faucet leaks around the stem rather than from the spigot, install new packing. You may want to install one of the newer nylon-covered or graphite-impregnated packings—their lubrication allows the faucet handle to turn more freely. Wrap one turn of this packing around the stem just beneath the packing nut (Fig. 1). Use three complete wraps if you're applying string-type packing. Some stems use O-rings, rather than packing. For these stems, replace the O-ring with a matching one to stop a leak. Hand tighten the packing nut, then tighten it another half-turn.
- 

Step #	2
--------	---

## REPAIRING A NOISY FAUCET

- A noisy washer-type faucet is usually caused by a loose seat washer. To stop the noise, first turn off the water and take the faucet apart as described previously. If the washer is loose, tighten it or replace it.
  - After threading the stem back into the faucet body, try moving it up and down. If it moves, the stem is worn and the entire faucet must be replaced.
  - Some faucets are noisy due to poor design and construction. The only way to solve this problem is to replace the faucet with a quality one.
-

Step #	<b>3</b>
--------	----------

## **REPAIRING WASHER-TYPE BATH AND SHOWER FAUCETS**

- To take apart a bath/shower faucet for repair, first turn off the water. Then take the faucet apart by removing its handle, escutcheon and packing nut. The packing nut may be buried deeply in the wall, requiring a socket wrench for removal.
  - Your bath and shower faucets may have a renewable seat that can be smoothed with a seat-dressing tool or removed and replaced using a seat wrench. For replacing and repacking the washer, follow the same instructions provided for a washer-type faucet. Some faucets may need a complete replacement of the combination stem/seat unit.
- 

Step #	<b>4</b>
--------	----------

## **WASHERLESS FAUCETS**

- A leak in a washerless faucet usually indicates that the working parts need replacing. Often, prepackaged repair kits are available. Kits may contain all the necessary parts, or may include only the specific parts that need replacing. Follow the instructions for installing the replacement parts. Washerless faucets on tubs and showers are repaired in the same way as those on sink and washbasins.
-

Step #	5
--------	---

## DIAPHRAGM-TYPE FAUCETS

- The diaphragm faucet is washerless but is similar to washer-type faucets. A rubber diaphragm between the stem and seat creates a straight-down, frictionless close. As with washer-type faucets, diaphragm faucets have two handles.
- Remove the stem by following the steps outlined for washer-type faucets. Instead of a washer on the end of the stem, you'll find a swiveling disc. If the rubber diaphragm doesn't come out with the stem, it is still inside the faucet.
- If the diaphragm didn't come out with the stem, use pliers to peel it from inside the faucet and pull it out. Install a new diaphragm around the swiveling disc, then replace the stem in the faucet.
- If the faucet is leaking around the stem, replace the stem's O-ring before reinstalling the stem.

Step #	6
--------	---

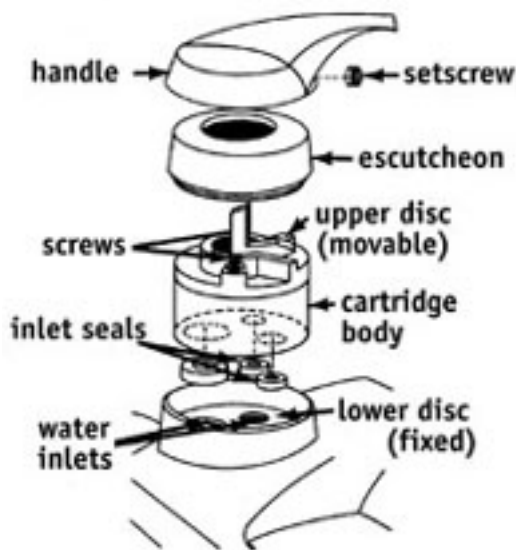

## DISC-TYPE FAUCETS

- Disc faucets may have one or two handles. The water is controlled by openings in the two discs. When the discs are rotated to align, the water flows; when the discs are misaligned, the water shuts off. If the discs wear, the worn discs cause the faucet to leak. Simply turning the handles harder will not stop the leak.
- To repair a leak in a *two-handle disc* faucet, turn off the water and remove the handle on the side that's leaking.
- Use pliers to pull the disc assembly out of the faucet (Fig. 4).

**FIG. 4** - Disc faucet

- Beneath the disc unit is the seat assembly, or seal. Replacing this special O-ring may stop the leak.
- You may need to install a whole new disc assembly for faucets that have been used over a long period of time. In this case, all moving parts of the faucet will have been replaced and should last as long as the original discs did. The parts of some disc units snap apart into a separate bonnet assembly and bottom cap.
- To repair a leaking *single-handle* disc, turn off both the hot and cold water and remove the handle to expose the disc assembly. Take out the screws to lift the assembly out of the faucet (Fig. 4).
- You'll notice that beneath the disc unit are three O-ring seals. Though unlikely, water could be leaking between the unit and one of these seals. In this case, you may be able to stop the leak by cleaning the disc assembly and faucet body and installing a new set of seals. If that doesn't work, the entire disc unit must be replaced. This will renew all moving parts.
- Replacing the unit is fairly simple. Place the three O-rings into their recesses in the bottom of the disc unit. Then install the unit and tighten the screws. Finally, replace the handle—and you're done!



## **BALL-TYPE SINGLE-LEVER FAUCETS**

- The single-handle faucet with a ball inside to control both hot and cold water may either leak at the spigot or at the handle. A handle leak is usually caused by improper adjusting-ring tension. Simply adjust the tension to stop the leak. Leaks at the handle can also result from a worn cam gasket. Dripping from the spigot is usually caused by worn spring-loaded, soft rubber seat assemblies.
- Parts for ball-type faucets are available in kits. Get the spring/seats kit for spigot leaks, or the complete kit for handle leaks. It may be advisable to use the complete kit to replace all working parts of the faucet at the same time. In any case, you'll need a kit containing the spanner/hex wrench for removing the handle (hex

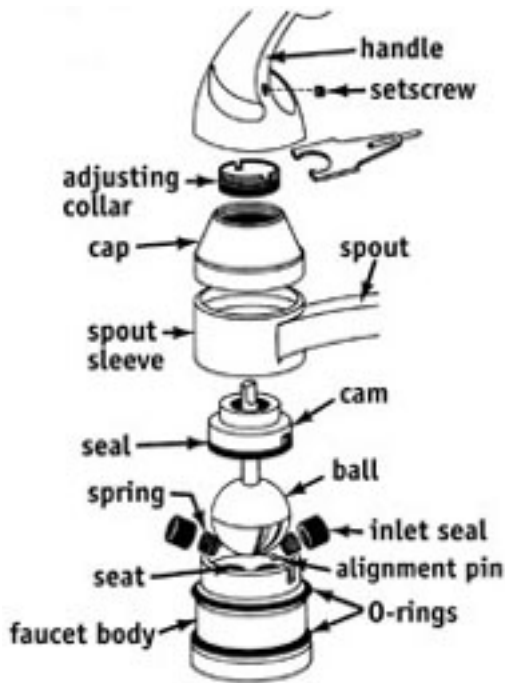

FIG. 5 - Ball faucet

end) and turning the adjusting ring (spanner end).

- Without turning the water off, loosen the handle set screw. Slide the handle from its stem.
- For a handle leak, try using the spanner wrench to tighten the adjusting collar (Fig. 5). Tighten it by turning the wrench and collar clockwise until the faucet doesn't leak when it is turned on and off. If the adjustment is too loose, the faucet will leak. If you turn it too tight, the handle will be hard to move. When the adjusting ring cannot be turned with the wrench, it is corroded. At this point, you will need to remove the cap to free the adjusting ring. (See next step.) You *must* turn the water off before removing the cap! Apply penetrating oil to the threads, remove the ring and clean all parts before reassembling.
- *Install the seats.* For faucet leaks at the spigot, you must install new rubber seats and springs. You *must* turn off the water to make this repair. Unscrew the chrome cap by turning it counterclockwise. If it won't turn easily, wrap electrical tape around the cap and turn it with pliers. The adjusting ring, which is threaded into the cap's center, will come off with it. For a seats/springs replacement, pull the ball up and out by its stem. The gasketed cam will come with it. Now you can locate the two rubber seats and springs inside the faucet body. Remove them with pliers or your fingers and install the new ones. The springs go into the holes first, and the cupped sides of the seats fit over the springs.
- *Service the ball.* If the ball is dirty or coated with scale, clean it or replace it with a new one. Both plastic and brass balls are available, but use a plastic one if your home has hard water.
- *Reassembly.* Put the ball and cam back into the faucet with the slot in the side of the ball fitting over the pin in the faucet body. Then make sure the tab on the cam slips down into the notch in the body. Not aligning the tab and notch is the number one cause for a faucet leaking after it is repaired. Finally, screw on the cap and adjust the ring as described in Step 2. If a properly adjusted ball-type faucet leaks at the cap, the cam and gasket must be replaced.
- *Swing spouts.* If a single-lever ball faucet leaks at the base, you should replace the O-rings. Remove the spout-retaining parts, as well as the spout. Wrap the spout-retaining nut with electrical tape to protect it, and remove the nut with a wrench or pliers by turning counterclockwise. Remove the spout by pulling it up and side-to-side. One or more O-rings should now be exposed (Fig.

5). Take the O-rings to your hardware or home center store to get matching O-rings for replacement. Clean any scale that appears on the spout base, faucet body, and the inside of the swinging spout. Install the new O-rings and reverse the steps above to reassemble the faucet.

Step #	8
--------	---

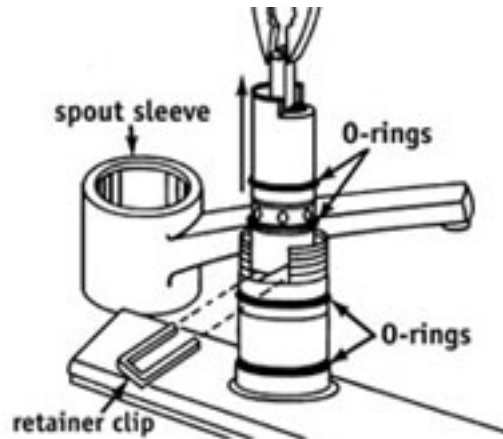

**FIG. 6** - To take apart a cartridge faucet, remove the spout sleeve and retainer clip, and lift out the cartridge.

## CARTRIDGE FAUCETS

- Cartridge faucets have only one moving part. The stem slides up and down to open and close the faucet and rotates to regulate the flow of hot and cold water. Any leaking requires replacement of the cartridge.
- First, turn off the water. To remove the cartridge, you'll need to remove the handle. This project can be like working a puzzle. If you have the manufacturer's instruction sheet for the faucet, you're ahead of the game. Without it, look for a retainer clip at the rear of the faucet just below the handle. Or, you may have to remove a set screw or snap-in "hot-cold" button and a handle pin or screw. On some faucets the swing spout must come off first. The retainer clip may be hiding beneath the handle inside a lift-out tube. Some cartridge faucets use two retainer clips—one by the handle and another by the cartridge. Retainer clips can be pried out with a screwdriver.
- Once the retainer clip is removed, the cartridge simply pulls out. Use pliers, as shown in Fig. 6. Install the new cartridge by pushing it into place with the flat arrow, or other mark upward. If you use a lubricant on the cartridge, make sure it's silicone grease.

## TOOL AND MATERIAL CHECKLIST

Smooth-jaw adjustable wrench

Screwdrivers, standard and Phillips

Pliers	Electrical tape
Pipe wrench	Faucet washers
Brass screws	Stem
Silicone grease or petroleum jelly	Seat dressing tool
Seat	Seat wrench
Silicone rubber sealant or pipe compound	Socket wrench
Packing	O-rings
Repair Kit	Cartridges
Disc assembly	Manufacturer's instruction sheet
Penetrating oil	Locking plier/wrench
Cleaning cloths	Hand cleaner

**Check your state and local codes before starting any project. Follow all safety precautions. Information in this brochure has been furnished by the National Retail Hardware Association (NRHA) and associated contributors. Every effort has been made to ensure accuracy and safety. Neither NRHA, any contributor nor the retailer can be held responsible for damages or injuries resulting from the use of the information in this document.**

***Ask for Other "Show-How" Instruction Sheets***

*Additional easy-to-use instruction sheets for home do-it-yourself projects are available from your local supplier of materials. Come in and ask for "Show-How" instructions when you get ready for that next handyman project!*